

Digital System Prototyping for Medical Devices

Great products are composed of great individual components that are increasingly assessed from every possible physical perspective. But optimally designed components do not necessarily result in optimal systems. Eventually, the components are assembled, powered, sensed and controlled as an integrated system, and must therefore be designed as a system to meet peak performance requirements and stringent safety standards. But building and testing integrated product systems and subsystems can be costly and may not identify optimal configurations and/or potential shortcomings.

Computational modeling is a recognized alternative to physical testing, but has historically been used in silos with minimal collaboration between various design disciplines. To address the needs of today's product development teams, Ansys has developed a multidomain, digital system prototyping platform that enables multispecialty teams with diverse engineering backgrounds to work in unison to achieve a deep understanding of integrated product behavior. This white paper summarizes the application of this platform to develop a digital system prototype of a wearable insulin pump.

/ What is Digital System Prototyping?

Digital system prototyping is defined here as a multidomain modeling approach that uses multiphysics and multiscale techniques to enable integrated system testing using simulation-based methods. The following terminology is commonly encountered when discussing digital system prototyping and is used throughout this paper:

Multiphysics simulation refers to the inclusion of multiple physical phenomena in a single computational model. This may or may not require multiple solvers. For example, a mechanical solver could be used to model stent deployment to a vessel wall, and then either a mechanical or computational fluid dynamics (CFD) solver could be used to model drug diffusion in the vessel tissue. In situations using more than one solver, the Ansys Workbench platform supports both 1-way coupling and 2-way co-simulation between physics solvers. This is a significant benefit of the Ansys portfolio versus point solutions, which requires an interpreter to manage data exchange at the interface(s) between model domains.

Multiscale modeling refers to simulations that include physical phenomena occurring at more than one temporal and/or spatial scale, the goal being to provide more realistic behavior at the desired scale. Each physical process may be modeled at different levels of detail (i.e., what effects are included in the model) and fidelity (i.e., how accurately those effects replicate physical behavior). For example, a model of transdermal drug delivery may use a 3-D CFD model to predict the spatial distribution of drug in the patch and skin coupled to a lumped-parameter model of pharmacokinetic processing by the human body. This example also shows the numerical solver required to incorporate the desired effects may vary at each scale.

Reduced-order models (ROMs) are compact, high-fidelity, computer-generated numerical representations that preserve the essential behavior and dominant effects of 2-D or 3-D simulations. ROMs rely on order reduction techniques to simplify higher-fidelity models. ROMs simulate physical processes in a fraction of the time required by full-scale simulations, while still preserving the essential accuracy of the solution. And while ROMs can be computationally expensive to construct, their downstream benefits include reduced storage requirements, computationally efficient system models and real-time simulation. Surgical simulators often use reduction techniques to model soft tissue response to surgical tools in real time.

Multidomain modeling incorporates a combination of the previously described modeling approaches, plus embedded software for displays and controllers, to represent system-level behaviors. This combined approach helps system engineers simultaneously understand the interactions between assemblies of components, subsystems and systems, ultimately leading to the identification of the optimal design of a product or process. A multidomain model can also help to ensure that the integrated system is able to manage safety hazards. For example, drug overdoses or underdoses are one of the most common device-related reasons that insulin pump users do not achieve their target blood glucose levels, and can occur for a variety of reasons. [1] A multidomain model can help to ensure that drug delivery performance requirements are satisfied under both normal and abnormal use conditions.

Using the above techniques, this white paper summarizes the application of the Ansys simulation platform to develop a digital system prototype of a wearable insulin pump. This will include not only single and multiphysics models of various pump components, but also a multidomain model of pump subsystems and their associated embedded software. The paper also reviews the opportunity to use virtual prototyping in global regulatory submissions.

/ Introduction

According to the United States Centers for Disease Control and Prevention (CDC), there were almost 22 million people living with diabetes in the United States in 2014 (see Figure 1). [2] This represents a fourfold increase since 1980 that is expected to double by 2050. The aging population is driving similar increases in other chronic diseases, including eye diseases such as age-related macular degeneration. [3]

These trends are helping to fuel the development of the healthcare Internet of Things (IoT), which is focused on improving patient care and outcomes through smart, connected medical devices that permit remote monitoring and automated (and optimal) treatment delivery. This sector is expected to contain more than 600 million connected devices managing our health and enabling health care delivery by 2020. [4] Such pervasive connectivity will permit the aggregation and analysis of large volumes of data that can guide actionable decisions regarding patient health.

Significant innovation in the areas of electrification and wireless connectivity will be required to enable this revolution. But other performance aspects cannot be neglected or compromised at the expense of improved connectivity and battery life. For example, drug delivery, closed-loop control, size reduction, and device durability will continue to be key concerns. Computational modeling provides a virtual platform that can address these critical design needs, resulting in an optimized product that is released more quickly when compared to development cycles built around physical prototyping alone. [5,6]

/ What is Diabetes?

Glucose is a type of sugar that the body uses for energy. Glucose and other nutrients are created when the carbohydrates in food, i.e., sugars and starches, are broken down in the digestive tract. Glucose moves from the digestive tract to the bloodstream and then to the interstitial fluid regions outside cells. Sugars require a hormone called insulin, which is created by the pancreas, to pass from the interstitial spaces into cell interiors to be used as energy. Patients with diabetes are not able to transport sugar molecules inside cells, which causes a buildup of glucose in the bloodstream. The two most common forms of diabetes are Type 1, in which the body loses its ability to create insulin, and Type 2, in which cells do not properly utilize insulin for glucose uptake. Type 2 diabetes is the most common form.

Americans Diagnosed with Diabetes

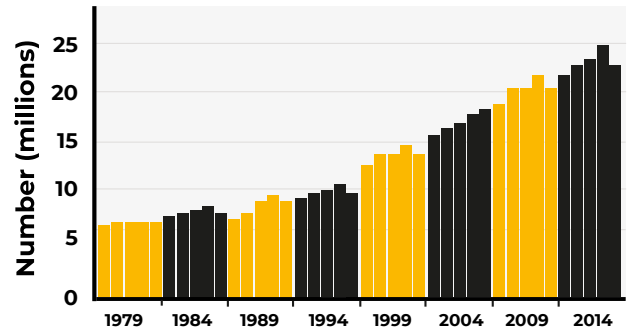

Figure 1. Number of Americans diagnosed with Type 1 or Type 2 diabetes. On average, 1.4 million adults are newly diagnosed as diabetic each year. Data from [2]

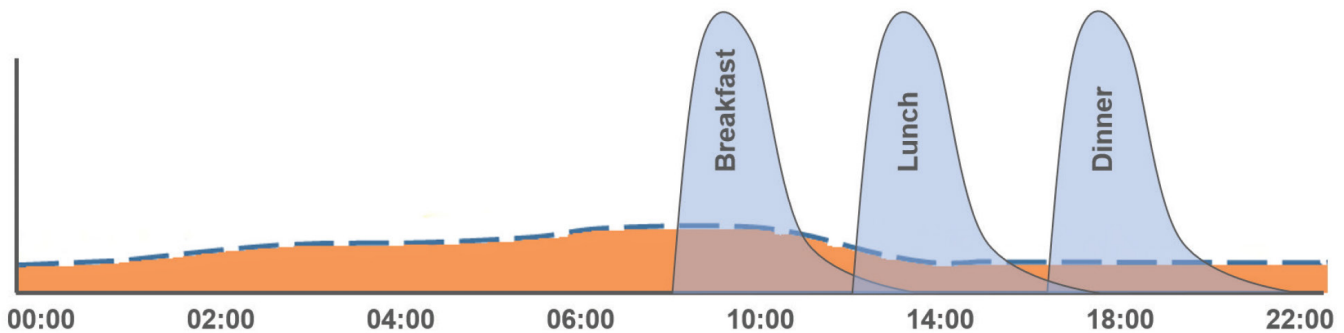

Figure 2. The two modes of insulin release: basal and bolus. Basal release (represented by the orange region below the dashed line) refers to the continuous release of insulin throughout the day. This manages blood glucose levels around a set-point. Bolus release (represented by the blue peaks) occurs in preparation for a large intake of carbohydrates at meal time.

/ Managing Diabetes

Diabetes management by the patient relies on the injection of insulin to maintain the blood glucose concentration within an acceptable range, typically 90 to 130 mg/dL. [7] As shown in Figure 2, modern wearable insulin pumps maintain blood glucose by continuously delivering insulin throughout the day (basal insulin release) and by delivering higher doses after meals and snacks (bolus insulin release). Basal insulin ensures that glucose released from the liver can provide energy to cells between meals and during sleep, while bolus insulin helps to process the larger amounts of glucose that enter the bloodstream after eating.

Today's insulin pump systems typically require users to measure their blood glucose and estimate carbohydrate intake in order to determine the appropriate insulin dosage. The future of these devices is a closed-loop insulin management system, i.e., an artificial pancreas, that continuously monitors and controls blood glucose levels throughout the day.



Figure 3. External view (left) and internal view (right) of an insulin pump digitally simulated on the Ansys platform.

/ Wearable Insulin Pump Overview

An insulin pump is a device about the size of a cellphone that contains a cartridge of rapid-acting insulin (see Figure 3 for an example). The pump has a screen for collecting and displaying patient information, buttons for programming the pump's internal computer, and a motor that pushes the insulin from a cartridge into the body through a catheter tube and (stainless steel) needle or (soft polymer) cannula. A Luer connector is typically used to securely attach the catheter tubing to the pump. Other pump components discussed in this white paper include an antenna for wireless communication with a blood glucose monitor (or a mobile phone), a battery and a printed circuit board (PCB).

/ Pump Design Considerations

Like many other medical devices, an insulin pump is composed of integrated systems of electronic, fluidic and mechanical components. These components, and their associated systems and subsystems, are driven by control algorithms that deliver a drug to the patient based on inputs collected through the user interface (display). Thus, understanding and optimizing pump performance requires single, multiple and multiphysics simulations, along with a platform that permits the integration of multidomain models with embedded software. For an insulin pump, the systems, subsystems, and components that help to ensure accurate and reliable drug delivery include:

- an infusion set, which is composed of the catheter and needle/cannula that provide the fluidic pathway for delivering a prescribed dose of insulin to the patient.
- a sensing system, which assists with detecting occlusion of the drug delivery path.
- a wireless communication system to exchange information with a peripheral monitoring device and/or health care provider, and
- the embedded software that controls the various actions of the pump and provides a patient-friendly interface.

Properly designing and optimizing each of these requires meticulous attention to detail since failure could come from a variety of sources, putting the patients' health at risk. The following sections review how these aspects (and others) can be modeled both individually and as connected systems, ultimately leading to a more robust and reliable device.

/ Drug Delivery

Insulin is delivered as a liquid suspension from a disposable cartridge inside the pump. After exiting the cartridge, the insulin solution passes through the infusion set, i.e., the catheter and then the cannula, and then into the subcutaneous (fat) layer of skin. Computational fluid dynamics tools such as Ansys Fluent predict the drug flow rate and pressure and shear forces encountered by the drug suspension throughout its history in the infusion set (see Figure 4a). Including skin in the model provides information about how the anatomical resistance of subcutaneous tissue will impact the pressure forces required to deliver an accurate drug dose. As shown in Figure 4b, the anisotropic nature of skin permeability lowers the penetration of the drug solution in the axial direction relative to the radial direction, causing the drug bolus to have a discoid shape.

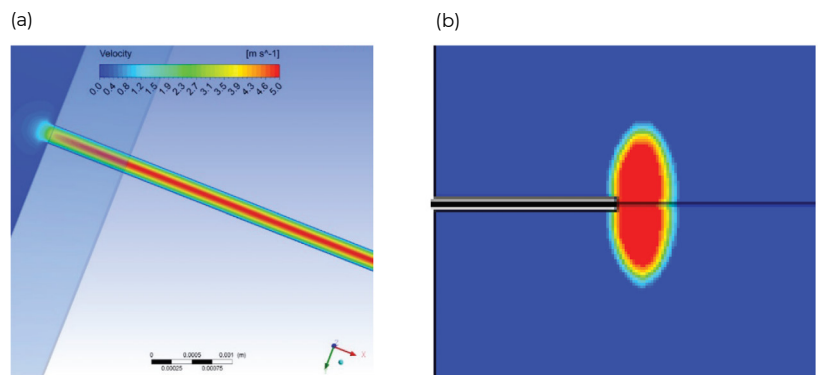

Figure 4. (a) Speed of insulin solution passing through a cannula into skin. (b) Drug dispersion in the subcutaneous (sub-q) space. Note how the anisotropic nature of sub-q tissue decreases penetration in the axial direction versus the radial direction.

And while not shown here, one could further extend the drug delivery model by coupling to a pharmacokinetic model of drug processing by the human body to predict the plasma insulin concentration with time. Such a multiscale approach links the drug infusion process to the treatment outcome, and enables the virtual design and analysis of closed-loop systems.

/ Kink Testing

Simulation can also help answer critical questions about the safety hazards of a device. For an insulin pump, obstruction of the flow path due to catheter kinking or occlusion can delay or even prevent insulin delivery.

Virtual kinking analysis begins with a model of catheter extrusion using Ansys Polyflow, followed by a bending simulation in Ansys Mechanical, and then pressure-flow analysis using Ansys Fluent (see Figure 5a). This analysis pipeline provides an understanding of the relationships between lumen cross-sectional shape, material selection, the manufacturing process and kink resistance. Using Ansys DesignXplorer, a virtual design of experiments (DOE) can be performed to determine the effect of catheter bend angle and flow rate on the pressure drop through the catheter. Finally, a ROM such as the one shown in figure 5b can be constructed from the DOE results, which can then be used in system models, e.g., to test the combined performance of the motor, hydraulics and embedded software (see Figure 11 for an example).

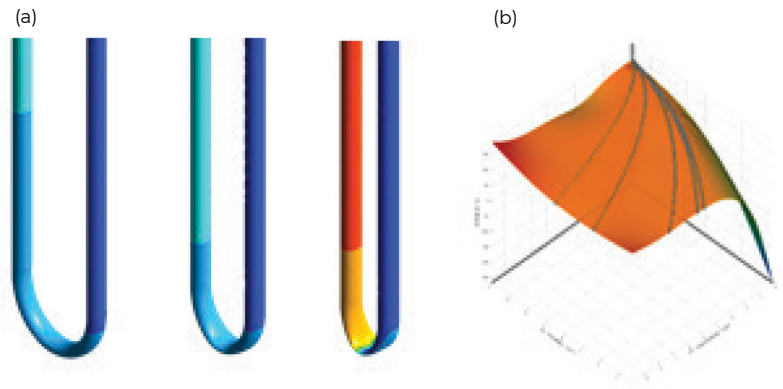

Figure 5. (a) Contours of pressure drop across a catheter tube for a range of bend angles. (b) A response surface summarizing a DOE study of pressure drop across the catheter for a range of flow rates and bend angles. This ROM can be exported from Ansys DesignXplorer for systems modeling.

/ Durability

Portable electronic devices are subject to a loss of functionality after experiencing an impact, which may damage the display, board or other components (see Figure 6 for an example). Therefore, it is crucial to understand how impacts encountered during manufacturing, shipping, or everyday use may affect product performance. Ansys Explicit STR can be used to identify the components that are prone to failure when dropped. Addressing these weak points in the design improves product durability, reducing warranty costs and making for a more reliable patient and/or clinician experience.

/ Antenna Design and Placement

Antenna performance is highly dependent on the relative position of the antenna with respect to other components within the pump housing, as well as interactions with the human body. Ansys HFSS models antenna performance, both as a component and when integrated into its operating environment. Figure 7a shows the preferred radiation directions of a planar inverted F antenna (PIFA) installed within the pump housing. Structures within the device, including the battery and touch screen, affect the efficiency of this antenna, and ultimately the reliability of the connection to any nearby devices. Additionally, link performance will be affected by interactions with human tissue (see Figure 7b). These interactions can be accounted for by examining performance as a function of position on (digital) human phantoms. This work can also be used to satisfy regulatory requirements, as was accomplished by Medtronic when they received Federal Communications Commission certification for specific absorption rate (SAR) safety when recharging a neurostimulator. [8]

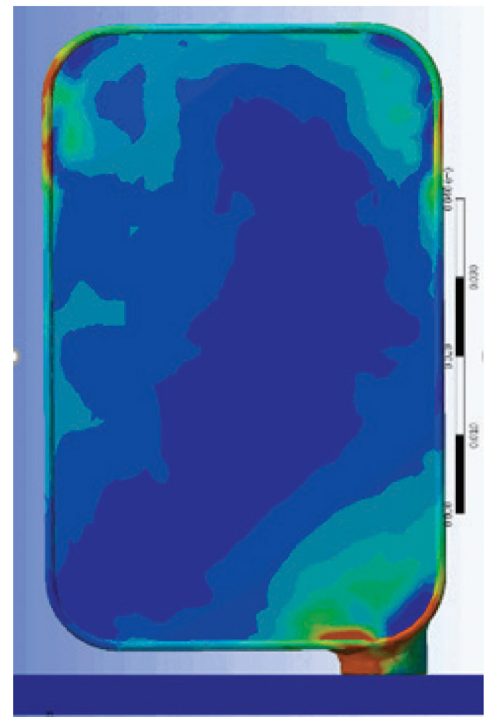
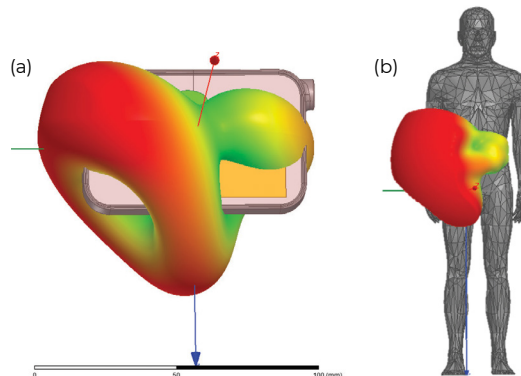

Figure 6. Virtual drop-test analysis reveals areas of the pump housing (in red) receiving the greatest stresses during impact.

Figure 7. (a) Electromagnetic (EM) field propagation in/around an insulin pump, illustrating the attenuation due to the various pump components, such as the PCB board, display, housing, etc. (b) An Ansys human phantom can be used to predict the interaction between the human body and the propagating EM field.



/ Wireless Interference

The ever-increasing prevalence of IoT-enabled products means that most patients will soon be wearing one or more internet-connected, health-related devices. These may range from a smart watch to an infusion pump to an implantable device, such as a pacemaker. Each of these have significant risk for interference and/or cross-talk. It is especially critical that nearby devices are not able to prevent communication between a life-sustaining device or controller. Ansys HFSS permits designers to analyze potential interactions between their products and other EM sources that may be encountered in the workplace or even a clinical setting, elucidating the potential for signal loss during day-to-day activities and even in extreme situations (see Figure 8). Additionally, Ansys EMIT combines the results of the electromagnetic simulations from HFSS with sophisticated radio models to predict potential interference mechanisms.

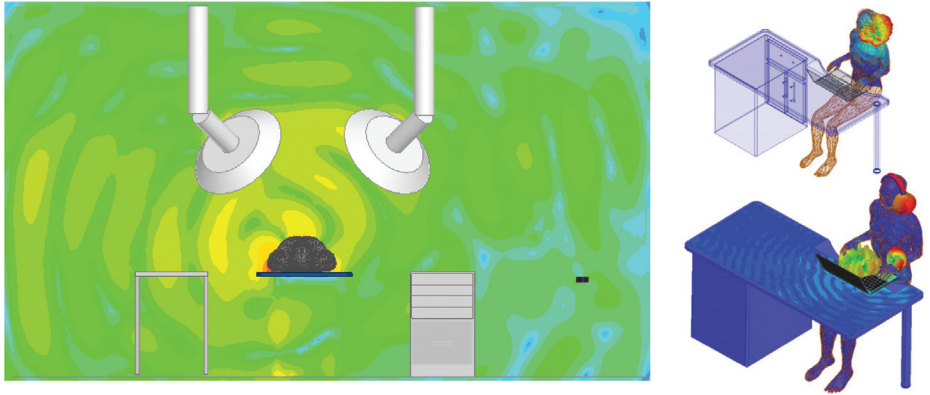

Figure 8. Wireless field propagation in the presence of external field sources present in a clinical setting (left) or in the work environment (right).

/ Electromagnetic Actuation

Electromagnetic actuation refers to the conversion of electrical energy into mechanical motion. This typically involves the use of (rotary) motors, (linear) actuators, or other smart materials to produce motion. In the case of infusion pumps, the mechanical output of the electromagnetic actuator is connected to a pump which moves insulin through the drug delivery circuit, where sources of resistance include the infusion set (catheter and cannula) and the tissue.

For electromechanical devices, providing the ability to do initial sizing, as well as more detailed finite element analysis (FEA) level design, is important for component optimization and for developing accurate reduced-order models that can be used in a system simulation. The performance characteristics of electromechanical devices that impact energy efficiency include torque and/or force capabilities, current and voltage requirements, as well as generated heat and operating temperatures. Tools such as Ansys RMxprt for initial motor sizing, Ansys Maxwell for detailed magnetic analysis and optimization, and Ansys Simplorer for system-level performance, provide a detailed understanding of electromechanical performance (see Figure 9). And depending on the degree of fidelity required, a system model in Simplorer can include various machine models from ANSYS RMxprt and Ansys Maxwell, and/or simple lumped-motor models from the Simplorer component libraries.

/ Power Management

Power management generally includes the controls and electrical circuits used to convert electrical power to mechanical power. For these systems, inclusion of the power semiconductors, such as MOSFETS and IGBTs, are used as switches to rapidly control the applied voltage and current from the electrical power source to the electromechanical device.

For low-power systems, efficient use of battery power is dependent on the implemented control system, circuit architecture, electromagnetics and mechanical loads of the system. Inclusion of embedded software, semiconductor models, thermal performance and reduced-order models for magnetic, mechanical and fluidic systems can be realized in Simplorer (see Figure 10).

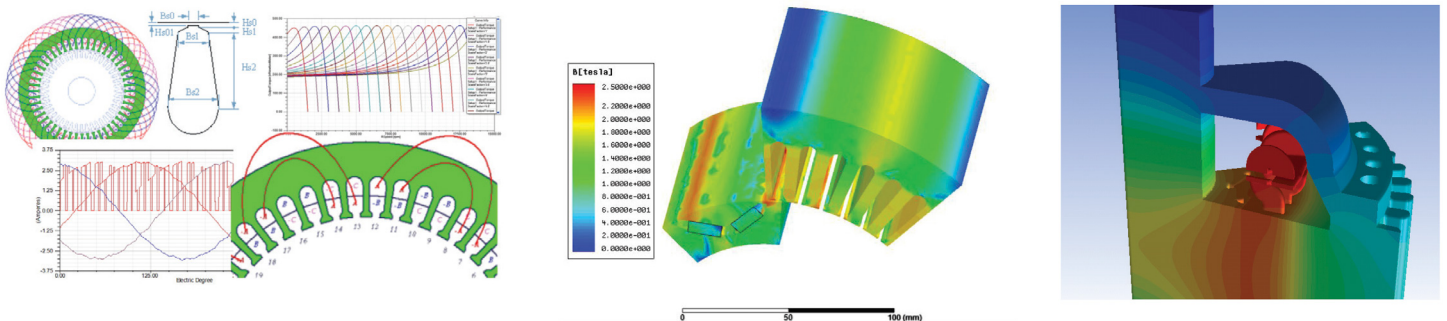

Figure 9. Initial motor sizing with RMxprt (top), detailed magnetic design with Maxwell (middle), and thermal performance with Ansys Mechanical or CFD (bottom).

Embedded Software

The growth in insulin pump functionality has led to a significant increase in the requirements for, and reliance on, the embedded software for displays and controllers. These include collecting and acting on patient data, monitoring two modes of drug delivery, transmitting patient data to a remote monitoring device or the cloud and managing alarms, to name only a few.

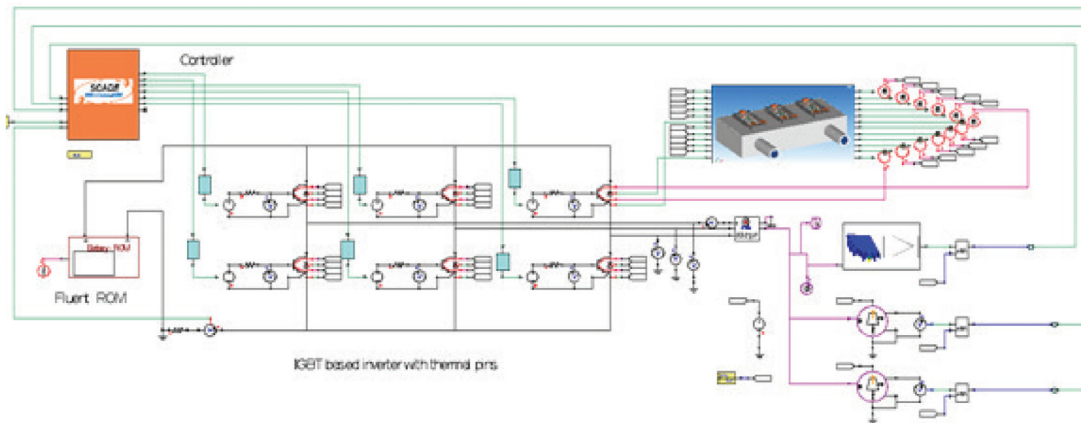

Figure 10. Power electronics, controls and reduced-order models can be combined in Ansys Simplorer to model and simulate power management systems.

Ansys SCADE software provides an understanding of embedded software behavior in the intended-use environment. This is made possible through operational and interactive executables that are exported from SCADE using the standard Functional Mock-up Interface (FMI) for integration into multidomain system-level tools such as Simplorer (see Figure 11). In this way, engineers are able to test their embedded software algorithms in a “software in the loop” configuration, which is crucial when verifying that the logic of the controllers and displays will work during normal use cases and adverse events, even before a single prototype is built.

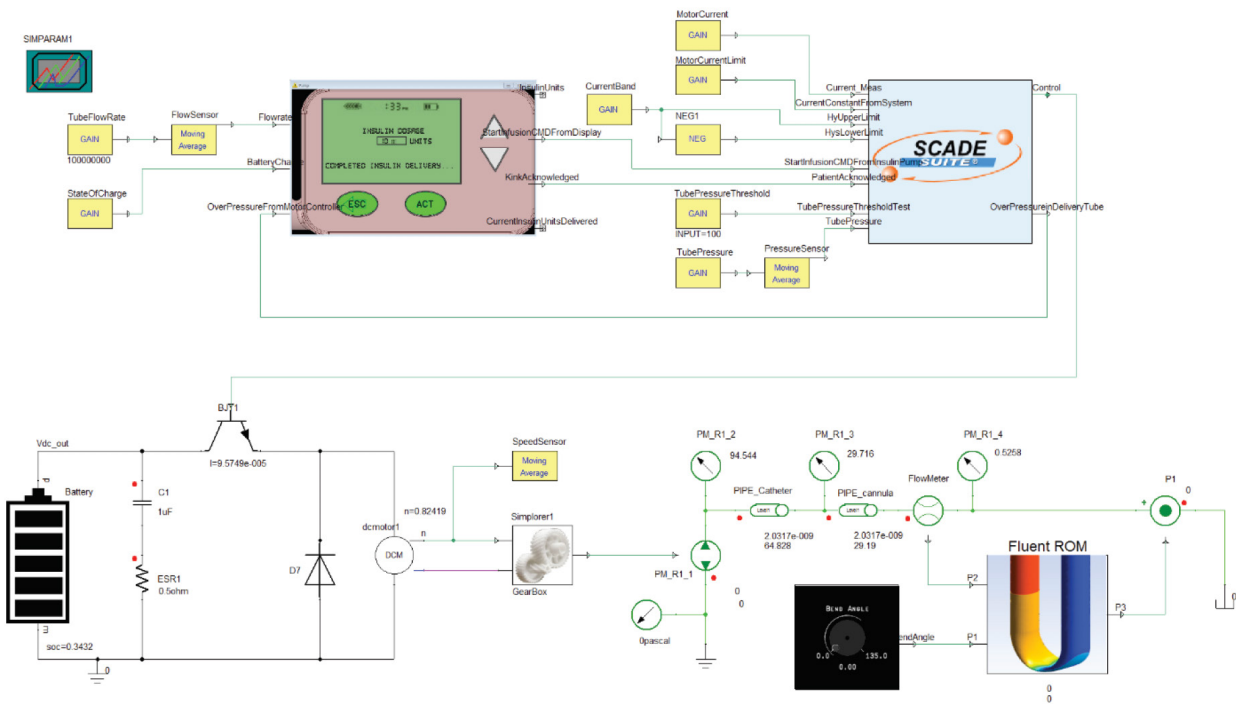

Figure 11. A multidomain model of an insulin pump that includes FMUs for the insulin pump display and controller (top row), and a DC motor circuit that powers a screw pump (bottom row, left) that drives flow through the fluidic circuit (bottom row, right).

Ansys SCADE Suite provides users with a graphical environment for embedded software development, testing and deployment (see Figure 12). Behind the SCADE graphical annotation is a formally defined design language that was created specifically for safety-critical embedded software. The strong semantics of this language are statically checked, ensuring that every SCADE Suite model is deterministic and meets critical safety properties. This, along with the certified code generation capability described next, provides assurance that the embedded software behavior being simulated is the same behavior that will be realized on the target.

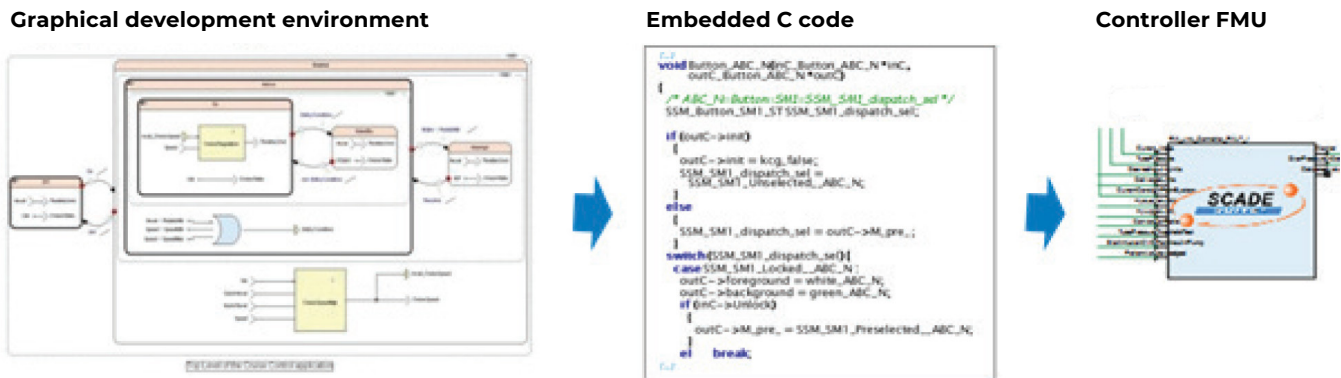

Figure 12. Example of the Ansys SCADE development environment (left), C-code generated by the Ansys SCADE Suite (middle) and controller FMU for digital system prototyping (right).

The SCADE Suite also provides an environment for developing and testing human-machine interfaces (HMI) or displays. In the case of an insulin pump, the display is expected to collect information regarding the users' current glycemic state and then provide a recommended insulin dose. This is accomplished by first collecting the carbohydrate intake and background blood glucose levels (see Figure 13). An insulin calculator then determines the appropriate units of insulin to be delivered, which is confirmed by the patient. The graphical nature of the SCADE development environment facilitates quick development of each individual "page" of the display as well as an understanding of the interactions between the various display pages.

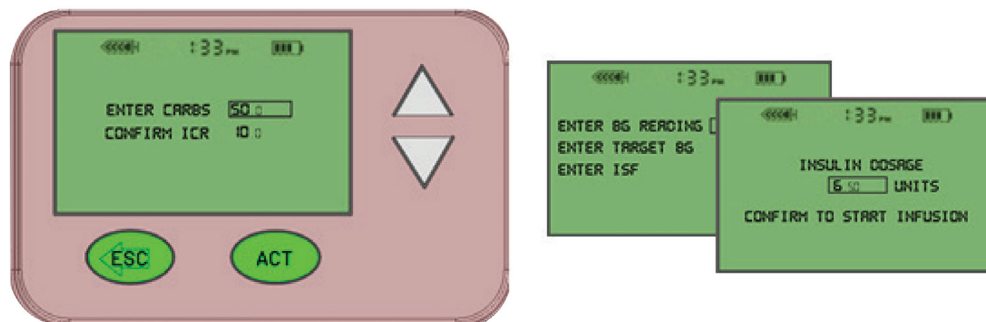

Figure 13. A sample insulin pump display (left) and two additional pages of the display (right) developed using Ansys SCADE Display.

Once the logic of a display and controller have been validated, the embedded software can be exported for direct integration on the target processor inside the infusion pump. SCADE Suite is the only software in the world that is guaranteed to output certified code, which saves significant time, costs and resources because of the reduction in software testing.

Lastly, SCADE Suite is established as a qualified code generator by leading regulatory authorities. This certification ensures that the generated code is correct to the logic and graphics design modules.

/ Regulatory Considerations

The concept of digital system prototyping is supported by global regulatory authorities and governmental institutions, who are evaluating the potential for computational modeling to accelerate not only product innovation but also regulatory review, while simultaneously increasing patient safety (see Figure 14). The U.S. Food and Drug Administration (FDA) was the first medical device regulator to formally recognize computational modeling as a fourth pillar of pre-market evaluation, the goal being to augment in vitro and in vivo testing and to foster a more robust understanding of device safety and efficacy. To this end, the FDA's Center for Devices and Radiological Health (CDRH) has identified computational modeling as a strategic priority consistently since 2011. [10] The CDRH has also published a guidance document that outlines reporting best practices for computational model results that appear in device submissions [11], and several CDHR staff are active members of the ASME V&V40 subcommittee, which is developing a risk-based approach for establishing the credibility of computational models used for decision-making. Such regulatory support and clarity is essential as we evolve toward the Medical Device Innovation Consortium's vision where in silico testing will represent over half of the safety and efficacy evidence for a medical device in the next 10+ years.

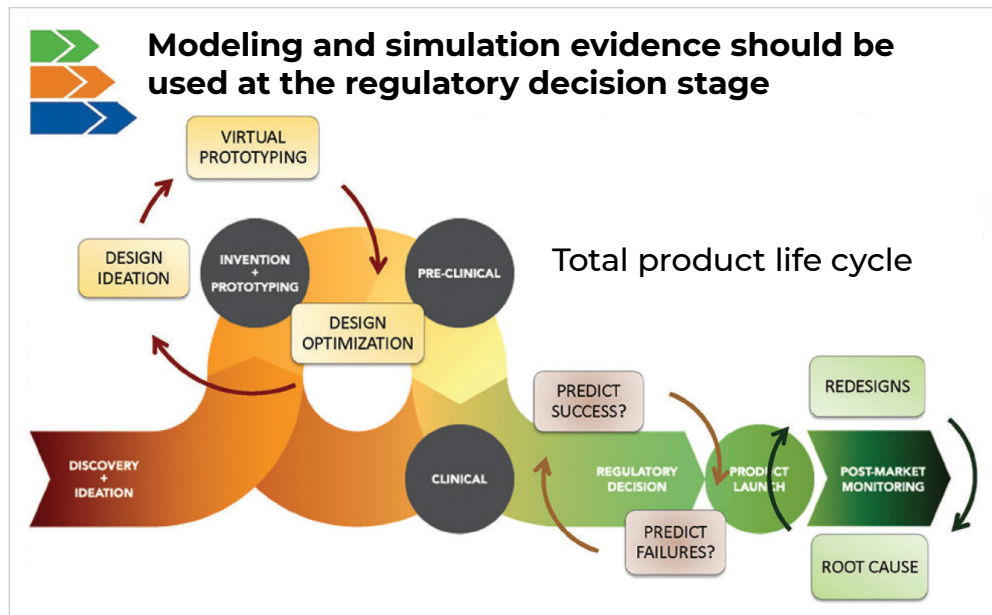

Figure 14. CDRH's view of computational modeling as a tool that can be used throughout the total product life cycle of a medical device, including the regulatory decision-making process. [9]

Support for computational modeling also extends beyond regulatory authorities to the legislative branches of government. For example, the United States Congress passed an appropriations bill in July 2015 that directed the FDA to explore greater use of in silico clinical trials to advance the development of new devices and drug therapies. [12] And the European Parliament implemented a similar change in their regulations in March 2016, requiring the European Medicines Agency (EMA) to develop a regulatory framework that can incorporate information from “alternative models,” such as computer models, in the evaluation of new medicinal products. [13]

Conclusions

Ensuring product integrity across every component, subsystem and system has never posed a greater challenge. Engineering organizations are addressing this challenge by increasing the use of modeling and simulation across the entire product architecture and throughout the product development cycle – from functional analysis through detailed design to system verification. This necessitates the use of a broad array of physics modeling and other software tools. And while each individual tool may be quite effective at performing deep comprehensive analysis, product groups often operate in silos, each using their own set of tools, engineering processes and associated expertise. The Ansys digital prototyping platform addresses the needs of interdisciplinary teams by bringing the industry’s strongest multiphysics portfolio together with system simulation and model-based software and systems engineering tools to provide a complete simulation-driven product development platform. This enables engineers from diverse backgrounds to share expertise and experience as they design the optimal product.

In conclusion, digital system prototyping software from Ansys helps medical device companies develop disruptive medical innovations faster and more reliably, partially replace clinical trials, and ensures greater success of a clinical trial through in silico simulation. Digital system prototyping tools from Ansys also enable engineering organizations to optimize the performance of the various physical components as well as the integrated systems of hardware and embedded software through improved collaboration across disciplines. This reduces (optimizes) physical testing, minimizes the occurrence of late-stage failures and ultimately accelerates the innovation and regulatory approval of today’s increasingly complex medical products.

References

1. Zhang, Yi, Jones, Paul L., and Jetley, Raoul. A Hazard Analysis for a Generic Insulin Infusion Pump. *J. Diabetes Sci. and Tech.* 2010, Volume 4, Issue 2, pp. 263-283.
2. Centers for Disease Control and Prevention Report, Long-term Trends in Diabetes, https://www.cdc.gov/diabetes/statistics/slides/long_term_trends.pdf, April 2016.
3. National Eye Institute. Age-Related Macular Degeneration Tables, <https://nei.nih.gov/eyedata/amd/tables#5>, retrieved Feb. 18, 2017.
4. BI Intelligence, Business Insider, Aug. 31, 2016, Here’s how the Internet of Things will explode by 2020, <http://www.businessinsider.com/iot-ecosystem-internet-of-things-forecasts-and-business-opportunities-2016-2>, retrieved Feb. 18, 2017.
5. Aberdeen Group Report, Why Engineering Simulation is Critical to your Smart Product’s Success in the Internet of Things. 2016.
6. Aberdeen Group Report, The Value of Virtual Simulation versus Traditional Methods. December 2014.

7. American Diabetes Association, 2004. Standards of Medical Care in Diabetes, 2004. *Diabetes Care* 27(Suppl. 1): pp: S15–S35.
8. Gaddam V. Charged Up. *Ansys Advantage*, Jan 2015. Vol IX, Issue 1, pp. 14-17.
9. Murray B, Bardot D. Simulation for Regulation. *Ansys Advantage*, Jan 2015. Vol IX, Issue 1, pp. 22-24.
10. US FDA, CDRH 2011 Strategic Priorities, Feb. 22, 2017, <https://www.fda.gov/downloads/AboutFDA/CentersOffices/OfficeofMedicalProductsandTobacco/CDRH/CDRHVisionandMission/UCM240367.pdf>. Retrieved Feb. 22, 2017.
11. US FDA, Reporting of Computational Modeling Studies in Medical Device Submissions, Guidance for Industry and Food and Drug Administration Staff, Sept. 21, 2016.
12. Agriculture, Rural Development, Food and Drug Administration, and Related Agencies Appropriations Bill, July 26, 2015.
13. Avicenna Alliance, EMA Regulation Vote result — major gains for in silico, <http://avicenna-alliance.com/news/news/ema-regulation-vote-result-major-gains-for-in-silico/>, retrieved Feb. 18, 2017.

ANSYS, Inc.
Southpointe
2600 Ansys Drive
Canonsburg, PA 15317
U.S.A.
724.746.3304
ansysinfo@ansys.com

If you've ever seen a rocket launch, flown on an airplane, driven a car, used a computer, touched a mobile device, crossed a bridge or put on wearable technology, chances are you've used a product where Ansys software played a critical role in its creation. Ansys is the global leader in engineering simulation. We help the world's most innovative companies deliver radically better products to their customers. By offering the best and broadest portfolio of engineering simulation software, we help them solve the most complex design challenges and engineer products limited only by imagination.

Visit www.ansys.com for more information.

Any and all ANSYS, Inc. brand, product, service and feature names, logos and slogans are registered trademarks or trademarks of ANSYS, Inc. or its subsidiaries in the United States or other countries. All other brand, product, service and feature names or trademarks are the property of their respective owners.

© 2020 ANSYS, Inc. All Rights Reserved.